



Flash-R | Flash-N

Armchair



Armchair Flash-R

Armchair Flash-R makes your places more elegant with its interwoven texture that hides any possible scratches on its surface. It is stackable up to six pieces. The backrest and seat, constructed in wicker, allows this armchair to combine well with various Tilia wicker products like Antares and Osaka tables. Flash is manufactured as a single piece, using gas injection technology.

It comes in six different colors; ivory white, cream, wood, wenge, coffee and black.

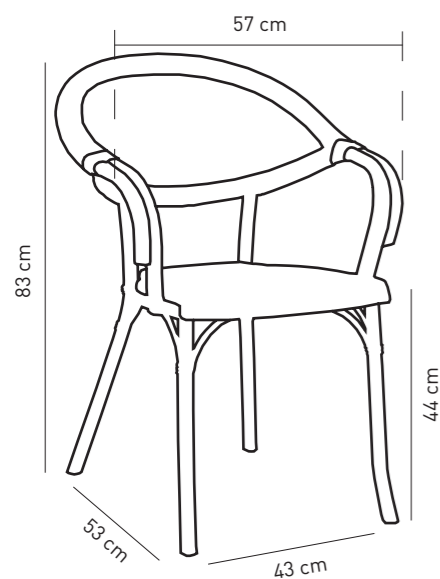

	Crtn	Net : 5,20 kg	Stack	Net : 5,20 kg
		Gross : 6,45 kg		Gross : 6,18 kg
	Loading Info	20' DC : 200 pcs	Loading Info	20' DC : 336 pcs
		40' DC : 400 pcs		40' DC : 742 pcs
		40' HC : 480 pcs		40' HC : 848 pcs
		90 cbm truck : 600 pcs		90 cbm truck : 1020 pcs
	Packaging Details	4 pcs	Packaging Details	14 - 16 pcs
		65 x 74 x 117 cm		65 x 87 x 242 cm
		0,56 cbm		1,36 cbm

Ivory White
101010262



Cream
101010223



Coffee
101010263



Wood
101010224



Wenge
101010225



Black
101010226



Anthracite
101012160



Stack







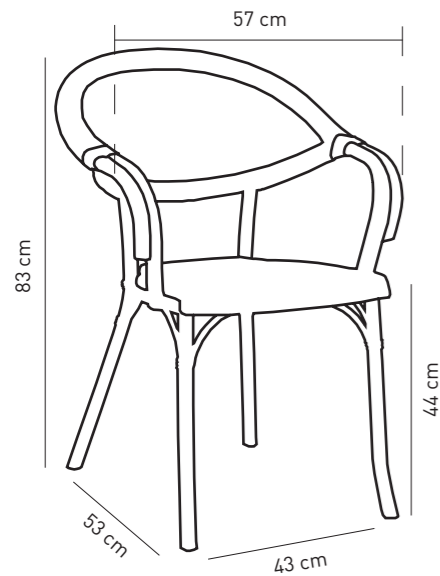

Armchair Flash-N

Armchair Flash -N makes your places more elegant with its fabric texture that hides any possible scratches on its surface. It is stackable up to six pieces. The backrest and seat, constructed in fabric, allows this armchair to combine well with various Tilia wicker products like Antares and Osaka tables. Flash is manufactured as a single piece, using gas injection technology.

It comes in six different body colors; ivory white, cream, wood, wenge, coffee, black which is combinable with 13 different net colours: beige, beige/coffee, linen, yellow/beige, gold/black, black, smoky, light green, yellow, red, blue, navy blue, darkgreen.



Crtn	Stack
 Net : 4,50 kg Gross : 5,80 kg	Net : 4,50 kg Gross : 5,20 kg
Loading Info	Loading Info
 20' DC : 200 pcs 40' DC : 400 pcs 40' HC : 480 pcs 90 cbm truck : 600 pcs	20' DC : 336 pcs 40' DC : 742 pcs 40' HC : 848 pcs 90 cbm truck : 1020 pcs
Packaging Details	Packaging Details
 4 pcs 65 x 74 x 117 cm 0,56 cbm	14 - 16 pcs 65 x 87 x 242 cm 1,36 cbm



Black/Black
101020862



Black/Turquoise
101020853



Black/Gold-Black
101020861



Black/Linen
101020864



Black/Navy Blue
101020854



Black/Silver-Black
101010270



Black/Smoky
101020860



Black/Yellow-Beige
101020859



Black/Yellow
101020857



Coffee/Beige-Coffee
101020870



Coffee/Black
101020876



Coffee/Gold-Black
101020875



Coffee/Linen
101020865



Coffee/Yellow-Beige
101020873



Coffee/Red
101020869



Body Colour Options



Net Fabric Colours

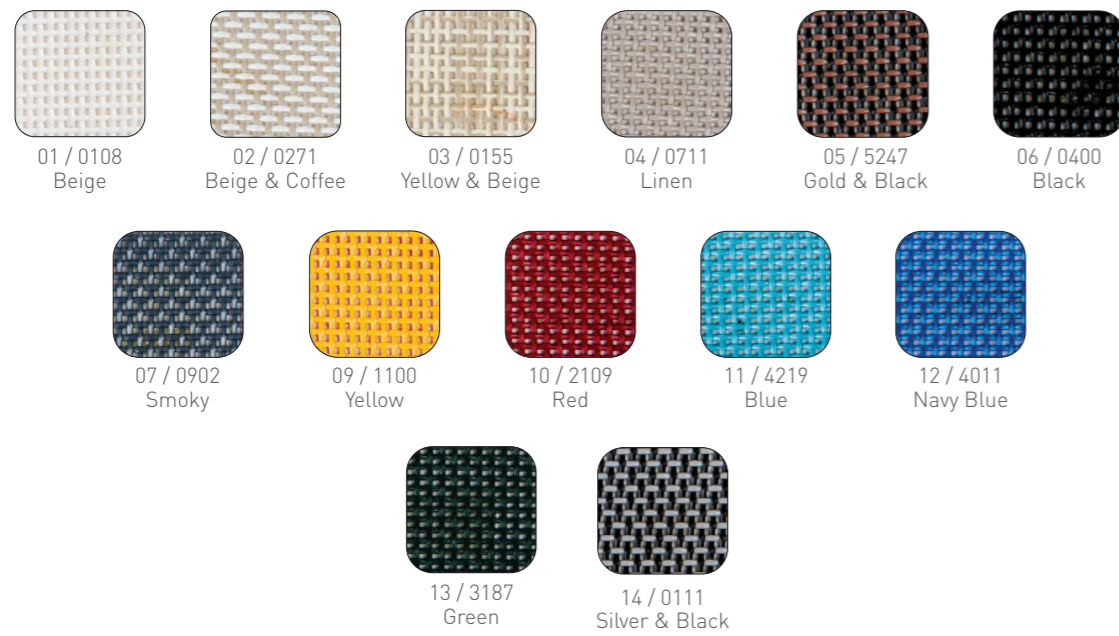

Warp Weave	: 6.10 yarns/cm
Weft Weave	: 5.30 yarns/cm
Fabric Weight	: 560 g/sqm
Warp Tensile Strength	: 310Kg/5cm
Weft Tensile Strength	: 270Kg/5cm
Thickness	: 1.15mm
Polyvinyl	: 70%
Polyester	: 30%

Savaş Plastik A.Ş.

Beysan Sanayi Sitesi Birlik Caddesi No:18
34524 Beylikdüzü, İstanbul, Türkiye



+90 850 346 65 65



+90 212 422 34 06



+90 212 422 46 25



www.tilia.com.tr



[/tiliafurniture](https://www.instagram.com/tiliafurniture)



[/TiliaFurniture](https://plus.google.com/+TiliaFurniture)



info@tilia.com.tr



[/tiliaContract](https://www.facebook.com/tiliaContract)



[/TiliaFurniture](https://www.pinterest.com/TiliaFurniture)



www.tilia.com.tr



Indoor 2019



Outdoor 2019