

ASSEMBLY SCHEMA Table Moon/Moon-S (Foldable)

Contents

a) 1 pc. Tabletop with Cross



□ MOON TABLETOP 60Ø

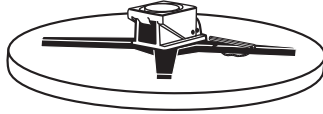

□ MOON-S TABLETOP 70Ø

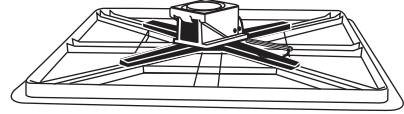

□ MOON TABLETOP 70x70cm

b) 1 pc Moon Leg

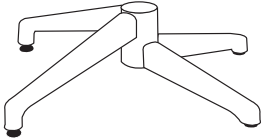

c) 1 pc Metal Tube



d) 1 pc Weight Mounted Driftbolt



e) 1 pc Washer



f) 1 pc Fibered Nut



g) 2 pcs M10 Nuts



1 Remove the pin from the mechanism.

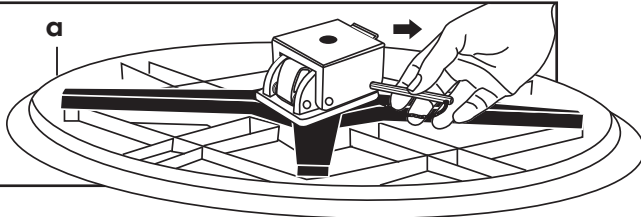

2 Lift the handle to release the mechanism, then lift the moving part of the mechanism together with handle until it's open completely.

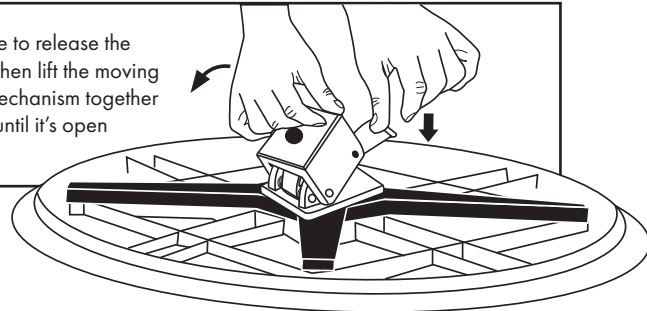

3 Remove fibered nut (f) and washer (e) and one of the nuts (g) from the driftbolt (d)



4 Place a nut (g) inside the slot behind the handle

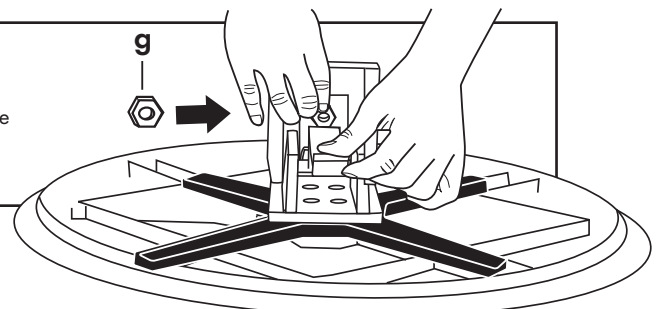

! Please be sure not to miss any screw holes and fasten all screws equally and tightly. Otherwise, you may face breakage or cracking during the time of usage.

5

Ensure there is one nut (g) available on the long side of the balance weight. Place the long side of the balance weight into the mechanism, then tighten the nut (g) with 17 wrench.

d g

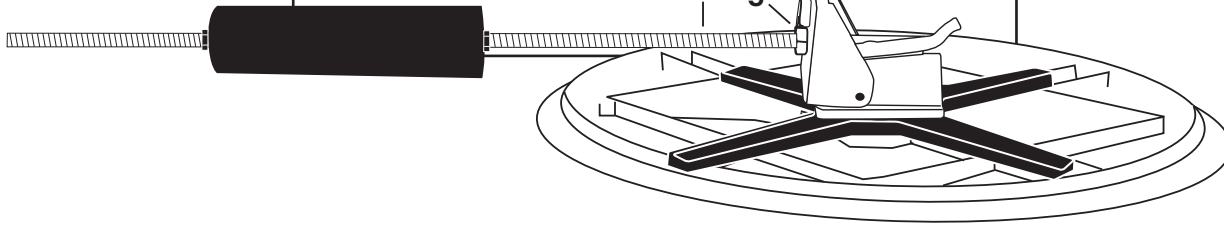

6

Close the mechanism together with the balanced weight (no interaction with handle required)

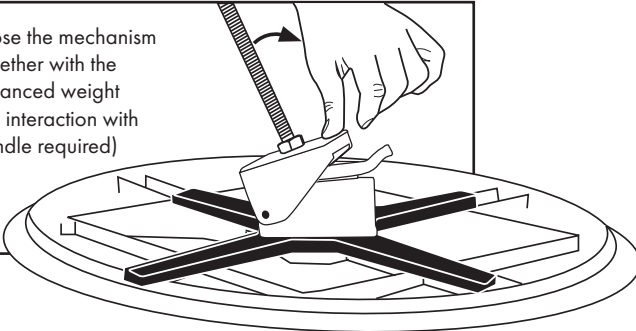

7

Install the pin to the mechanism

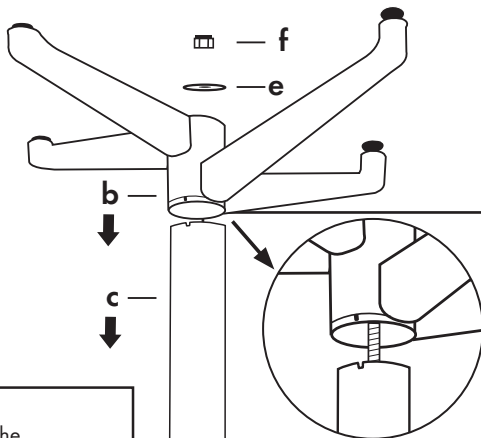
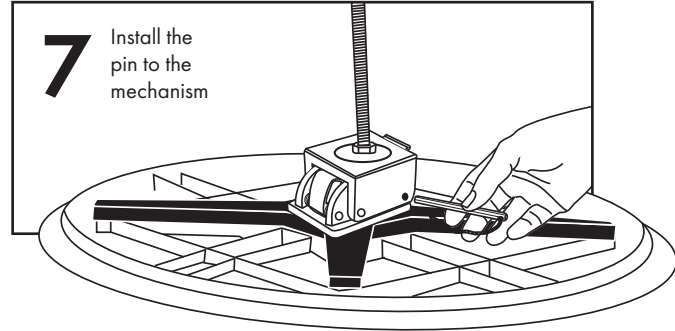

! The direction of closure of the table and the notch of the leg must be in the same direction

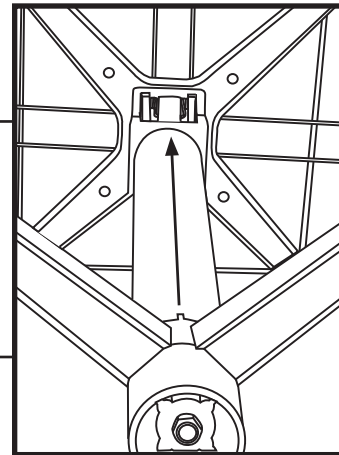

8

Place the aluminum tube (c) until it covers the driftbolt with balance weight (d). Then place the table leg (b) under the aluminum tube, make sure to fit the notch. Then insert the washer (e) and fibered nut (f).

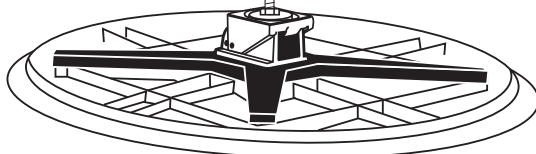

9

Tighten the nut with a 17 wrench or ratchet.

